



## AUTORIPARABILE

Dopo un urto accidentale, si inserisce automaticamente nella propria sede di scorrimento, evitando l'intervento del servizio tecnico. Ritorna immediatamente operativa e non interrompe il vostro ciclo produttivo.

## SICURA

Completamente priva di barre o parti rigide, garantisce in qualsiasi situazione la sicurezza del vostro personale e dei mezzi.

## VELOCE

L'assenza delle barre di irrigidimento ed un comando di variatore di velocità (Inverter), permette una velocità di ciclo, fino a 2,5 m/s.



## ERMETICA - RESISTENTE

Lo scorrimento del telo, guidato lateralmente da profili auto-lubrificanti garantisce tenuta ermetica ed una resistenza al

## SELF-REPAIRING

After an accidental impact, it automatically returns to its sliding guides, avoiding any technical servicing intervention. Immediately starts to function again and does not interrupt your production cycle.

## SAFE

Completely free of bars or rigid parts, ensures the safety of your staff and vehicles in any situation.

## FAST

No stiffening bars and an inverter for speed control, allows a cycle speed up to 2.5 m/s.

## AIRTIGHT - RESISTENT

Self-lubricating side sections guide the sliding of the curtain ensuring airtightness and wind resistance of 80Kg/m<sup>2</sup>



CHIUSURE RAPIDE AUTORIPARANTI - HIGH SPEED SELF-REPAIRING DOOR

LEGENDA:

- 1. Motorizzazione fuori vano
- 2. Rullo avvolgitore
- 3. Carter superiore
- 4. Lampeggiante
- 5. Telo in PVC
- 6. Oblò 850x300 in Cristal Anti U.V.
- 7. Guida di scorrimento in poliestere
- 8. Nottolini di tenuta in poliestere
- 9. Bordo sensibile
- 10. Fotocellula
- 11. Montanti
- 12. Quadro di comando

KEY:

- 1. Drive unit outside doorway
- 2. Winder roller
- 3. Upper guard
- 4. Flashing light
- 5. PVC curtain
- 6. Anti U.V. "Cristall" window 850x300
- 7. Polyester guide
- 8. Polyester latches
- 9. Sensitive edge
- 10. Photoelectric cell
- 11. Jamb
- 12. Control board

-STRUTTURA metallica zincata autoportante

- MONTANTI laterali sagomati dotati di guide di scorrimento del telo in materiale autolubrificante

-TELO totalmente senza barre, con sistema di tenuta laterale a inserti in materiale polimerico autolubrificante

- MOTORIZZAZIONE autofrenante trifase adatta ad un servizio continuo, comandata da centrale ad Inverter con rallentamenti a finecorsa

-FINECORSA meccanico a giri

-QUADRO DI COMANDO a norme CE con contenitore metallico (dim. 300x400x150) IP. 65

-FOTOCELLULE di sicurezza a raggi infrarossi

-COSTA SENSIBILE elettronica

CARATTERISTICHE TECNICHE

- VELOCITA' fino a 2 m/s
- TENUTA VENTO classe 2
- TEMPERATURA D'ESERCIZIO -30° +70°

-STRUCTURE galvanised metallic, self-supporting

-JAMBS shaped, fitted with self-lubricating curtain guides

-CURTAIN completely bar-free, with side seal system with self-lubricating polymeric inserts

-DRIVE UNIT three-phase, autobraking suitable for continuous use, controlled by inverter unit with limit switch for slowing down.

-LIMIT SWITCH mechanical, rpm

-CONTROL BOARD of CE standard with metal case, (dim. 300x400x150) IP. 65

-PHOTOELECTRIC CELLS infrared

-SENSITIVE EDGE electromechanical

TECHNICAL SPECIFICATIONS

- SPEED up to 2m/s
- WIND RESISTANT class 2
- OPERATIVE TEMPERATURE -30° +70°



TELO antistrappo 3000 n/s cm ca in ordito e trama, autoestinguente, classe 2.

CURTAIN rip-proof of warp and weft fabric approx 3,000 n/cm, fire retardant, class 2

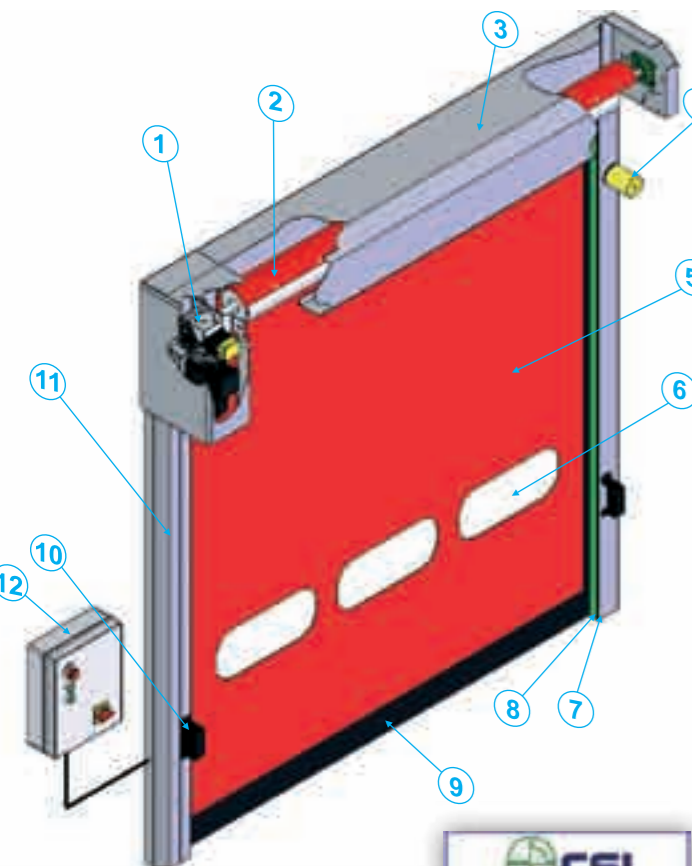

La porta "DYNAMIC ROLL" è conforme alle normative europee 13241/CE

The "DYNAMIC ROLL" door complies with EU standards 13241/CE



Montaggio fuori vano

Assembly outside

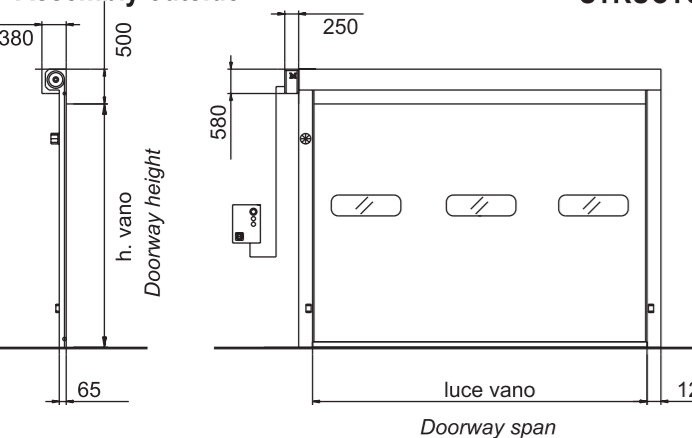

INGOMBRI STRUTTURALI

STRUCTURAL DIMENSIONS

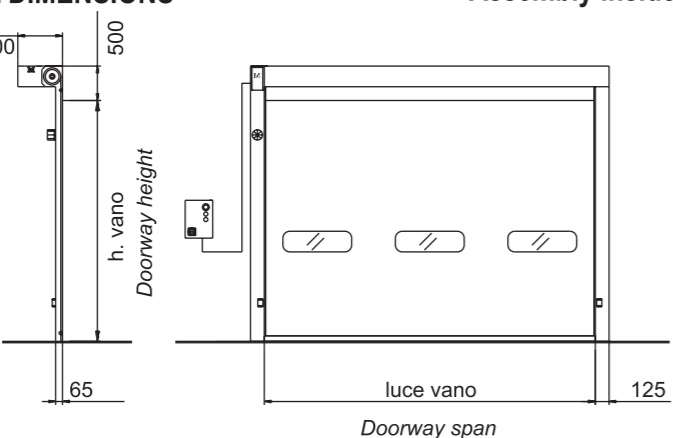

Montaggio in vano

Assembly inside

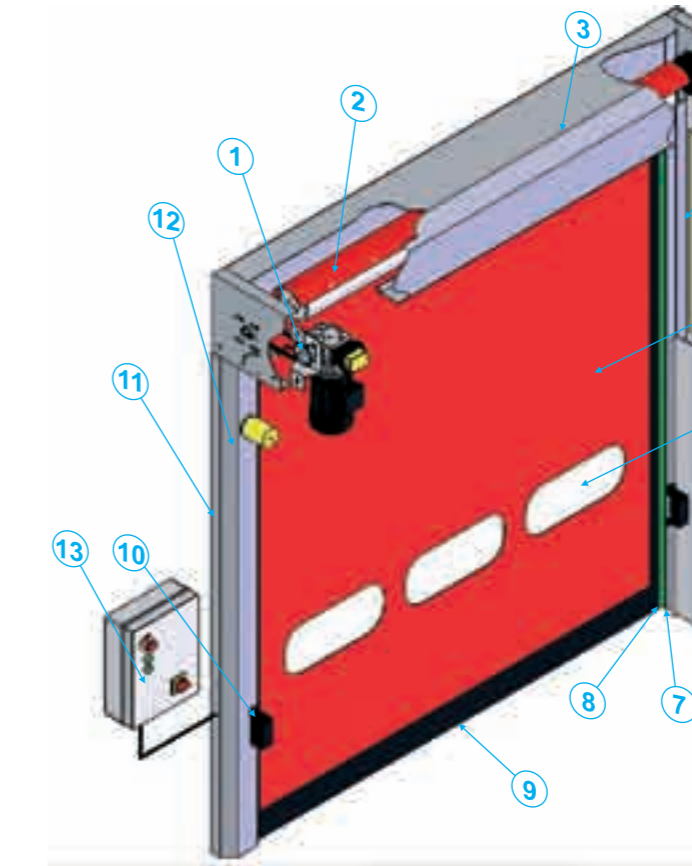

La porta "DYNAMIC BOS" è conforme alle normative europee 13241/CE

The "DYNAMIC BOS" door complies with EU standards 13241/CE



In assenza di tensione libera il passaggio senza alcun comando.

In case of a power failure, this system allows transit in-and-out with no manual control necessary.



Montaggio fuori vano

Assembly outside

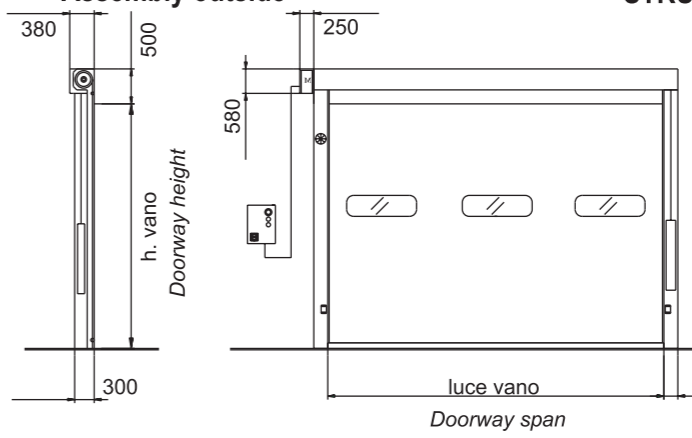

INGOMBRI STRUTTURALI

STRUCTURAL DIMENSIONS

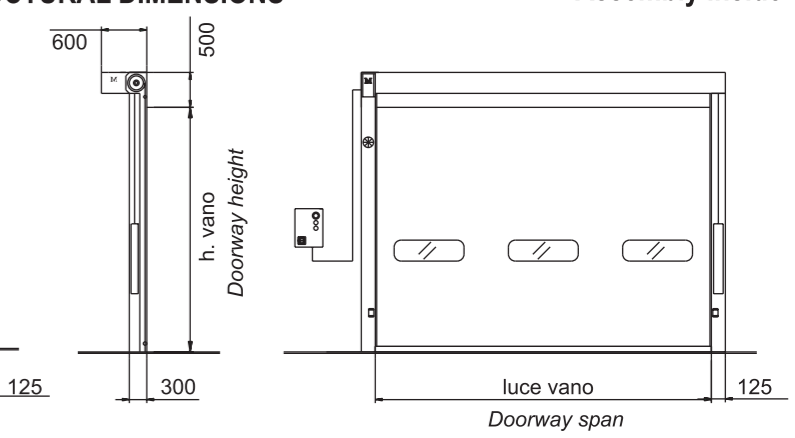

Montaggio in vano

Assembly inside